

Name Answers on last page

Circle the best answer (if multiple choice) or circle your final answer after showing ALL of your work (short answer). Please make sure your work is neat and organized and make sure to write your final answers with units and using the correct number of significant digits. Good luck!

- 1) The figure shows four Gaussian surfaces surrounding a distribution of charges.

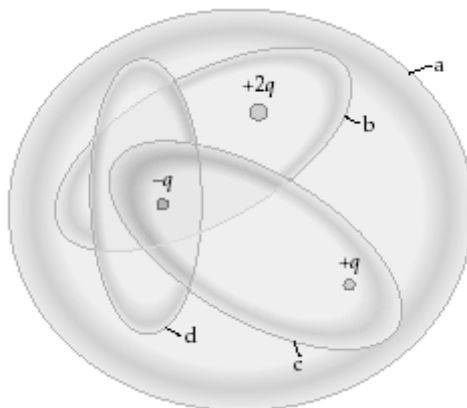

- (a) Which Gaussian surfaces have an electric flux of  $+q/\epsilon_0$  through them?  
 (b) Which Gaussian surfaces have no electric flux through them?
- 2) A cylindrical wire has a resistance  $R$  and resistivity  $\rho$ . If its length and diameter are BOTH cut in half,
- (a) what will be its resistance?  
 A)  $4R$   
 B)  $2R$   
 C)  $R$   
 D)  $R/2$   
 E)  $R/4$
- (b) what will be its resistivity?  
 A)  $4\rho$   
 B)  $2\rho$   
 C)  $\rho$   
 D)  $\rho/2$   
 E)  $\rho/4$

3) A conducting sphere of radius  $R$  carries an excess positive charge and is very far from any other charges. Which one of the following graphs best illustrates the potential (relative to infinity) produced by this sphere as a function of the distance  $r$  from the center of the sphere?

A)

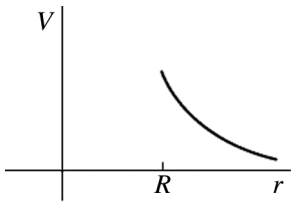

B)

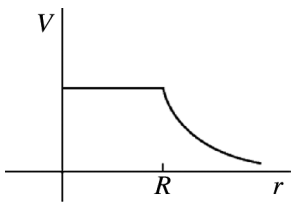

C)

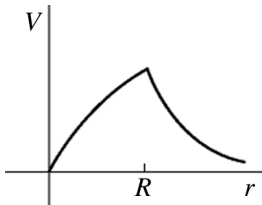

D)

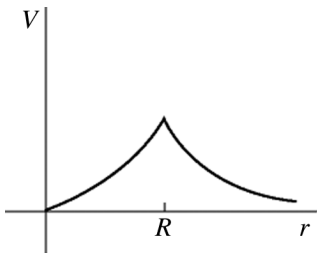

E)

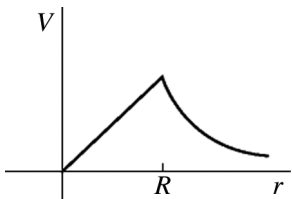

- 4) A hollow conducting spherical shell has radii of 0.80 m and 1.20 m, as shown in the figure. The sphere carries a net excess charge of  $-500 \text{ nC}$ . A point charge of  $+300 \text{ nC}$  is present at the center. ( $k = 1/4\pi\epsilon_0 = 8.99 \times 10^9 \text{ N} \cdot \text{m}^2/\text{C}$ )
- What is the surface charge density,  $\sigma$ , on the inner surface of the conducting shell?
  - Determine the electric field 3.0 cm from the point charge at the center of the sphere.

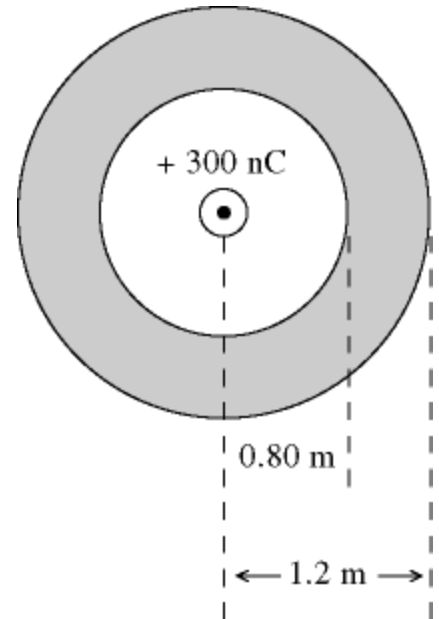

- 5) In a certain region, the electric potential due to a charge distribution is given by the equation  $V(x,y) = 2xy - x^2 - y$ , where  $x$  and  $y$  are measured in meters and  $V$  is in volts. At which point  $\vec{r} = (x,y)$ , is the electric field equal to zero?

- 6) The cross section of a long cylindrical coaxial cable is shown in the figure, with radii as given. The linear charge density on the inner conductor is  $-40 \text{ nC/m}$  and the linear charge density on the outer conductor is  $-50 \text{ nC/m}$ . The inner and outer cylindrical surfaces are respectively denoted by  $A, B, C,$  and  $D,$  as shown. ( $\epsilon_0 = 8.85 \times 10^{-12} \text{ C}^2/\text{N} \cdot \text{m}^2$ )

- (a) Determine the electric field at a distance of  $r = 29 \text{ mm}$  from the center of the cable.  
 (b) Determine the potential difference between  $A$  and  $B$ .  
 (c) Determine the potential difference between  $B$  and  $C$ .

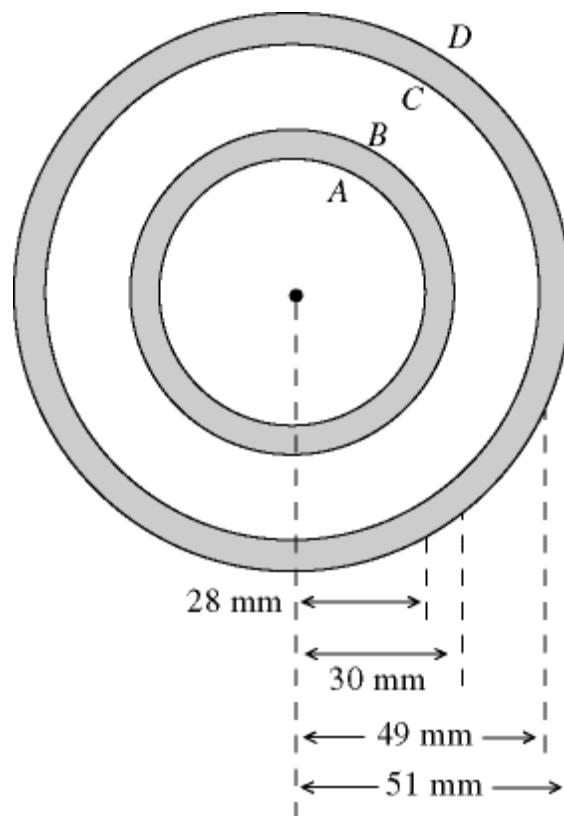

- 7) Two large conducting parallel plates *A* and *B* are separated by 2.4 m. A uniform field of 1500 V/m, in the positive *x*-direction, is produced by charges on the plates. The center plane at  $x = 0.00$  m is an equipotential surface on which  $V = 0$ . An electron is projected from  $x = 0.00$  m, with an initial velocity of  $1.0 \times 10^7$  m/s perpendicular to the plates in the positive *x*-direction, as shown in the figure. ( $e = 1.60 \times 10^{-19}$  C,  $m_{e1} = 9.11 \times 10^{-31}$  kg)
- (a) What is the direction of the acceleration of the electron?
- (b) What is the kinetic energy of the electron as it reaches plate *A*?

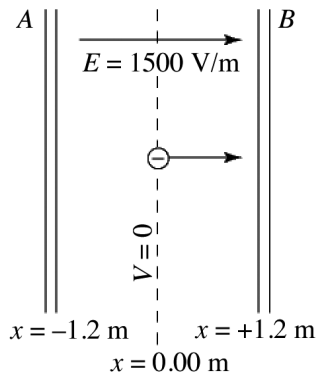

- 8) Four resistors are connected across an 8-V DC battery as shown in the figure.
- (a) Determine the total resistance of the circuit.
- (b) Determine the current through the 9  $\Omega$  resistor.
- (c) Determine the power dissipated as heat in the 3  $\Omega$  resistor.

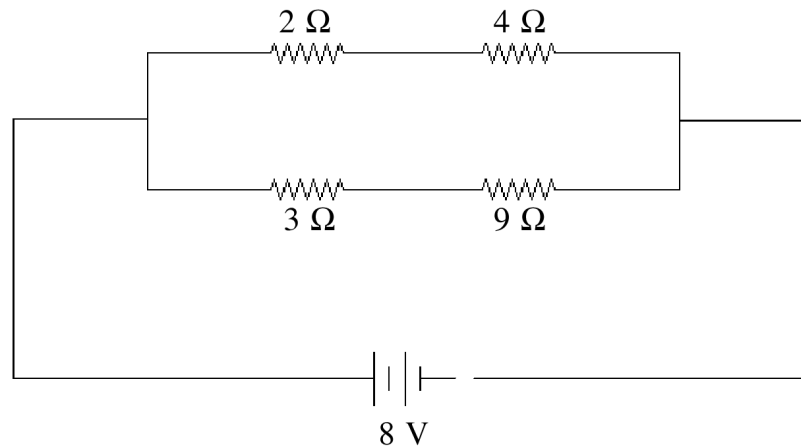

9) A multiloop circuit is shown in the figure. It is not necessary to solve the entire circuit. Determine the current  $I_2$ .

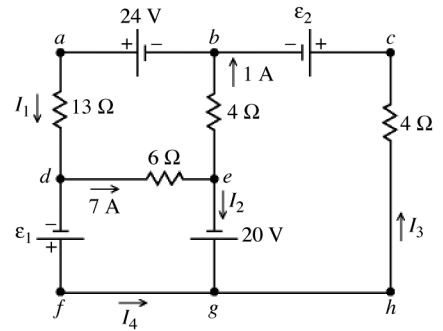

10) A multiloop circuit is shown in the figure. Some circuit quantities are not labeled. It is not necessary to solve the entire circuit. The emf  $\mathcal{E}$  is closest to

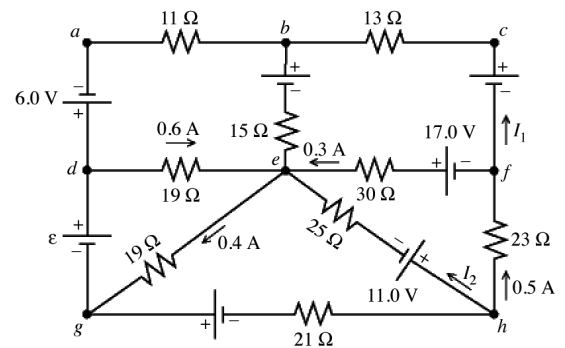

11) For the circuit shown in the figure, the capacitors are all initially uncharged, the connecting leads have no resistance, the battery has no appreciable internal resistance, and the switch  $S$  is originally open.

(a) Just after closing the switch  $S$ , what is the current in the  $15.0\text{-}\Omega$  resistor?

(b) After the switch  $S$  has been closed for a very long time, what is the potential difference across the  $28.0\text{-}\mu\text{F}$  capacitor?

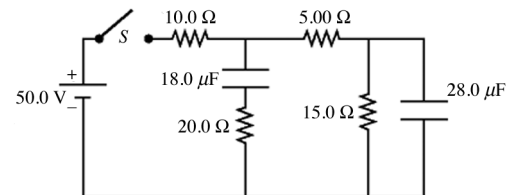

### Trigonometry

$$(1) \cos(\theta) = \frac{adj}{hyp}, \sin(\theta) = \frac{opp}{hyp}, \tan(\theta) = \frac{opp}{adj}$$

$$(2) hyp^2 = adj^2 + opp^2$$

### Quadratic Formula:

$$Ax^2 + Bx + C = 0 \Rightarrow x = \frac{-B \pm \sqrt{B^2 - 4AC}}{2A}$$

### Newton's Laws:

$$(1) \vec{F}_{net} = 0 \Rightarrow \vec{a} = 0$$

$$(2) \vec{F}_{net} = m\vec{a}$$

$$(3) \vec{F}_{AB} = -\vec{F}_{BA}$$

### Vector Products:

$$(1) \vec{A} \cdot \vec{B} = |\vec{A}||\vec{B}|\cos\phi_{AB} = A_x B_x + A_y B_y + A_z B_z$$

$$(2) |\vec{A} \times \vec{B}| = |\vec{A}||\vec{B}|\sin\phi_{AB}$$

### Coulomb's Law:

$$(1) \vec{F}_{1,2} = \frac{kq_1 q_2}{r^2} \hat{r} \quad (\text{Force: pt. charges})$$

$$(2) \vec{E} = \frac{\vec{F}}{q_0}$$

$$(3) |\vec{E}| = \int \frac{k dq}{r^2} \quad (\text{Cont. charge dist.})$$

### Electric Dipoles:

$$(1) \vec{p} = q\vec{d}$$

$$(2) \vec{\tau} = \vec{p} \times \vec{E}$$

$$(3) U = -\vec{p} \cdot \vec{E}$$

### Gauss's Law:

$$(1) \Phi_E = \iint \vec{E} \cdot d\vec{A}$$

$$(2) \oiint \vec{E} \cdot d\vec{A} = \frac{Q_{enc}}{\epsilon_0}$$

### (3) Electric Potential

$$W_{a \rightarrow b} = U_a - U_b = -(U_b - U_a) = -\Delta U \quad (\text{work done by a conservative force})$$

$$U = \frac{1}{4\pi\epsilon_0} \frac{qq_0}{r} \quad (\text{electric potential energy of two point charges } q \text{ and } q_0)$$

$$U = \frac{q_0}{4\pi\epsilon_0} \left( \frac{q_1}{r_1} + \frac{q_2}{r_2} + \frac{q_3}{r_3} + \dots \right) = \frac{q_0}{4\pi\epsilon_0} \sum_i \frac{q_i}{r_i} \quad (\text{point charge } q_0 \text{ and collection of charges } q_i)$$

$$V = \frac{U}{q_0} = \frac{1}{4\pi\epsilon_0} \frac{q}{r} \quad (\text{potential due to a point charge})$$

$$V = \frac{U}{q_0} = \frac{1}{4\pi\epsilon_0} \sum_i \frac{q_i}{r_i} \quad (\text{potential due to a collection of point charge})$$

$$V = \frac{1}{4\pi\epsilon_0} \int \frac{dq}{r} \quad (\text{potential due to a continuous distribution of charge})$$

$$V_a - V_b = \int_a^b \vec{E} \cdot d\vec{l} = \int_a^b E \cos\phi \, dl \quad (\text{potential difference as an integral})$$

$$E_x = -\frac{\partial V}{\partial x} \quad E_y = -\frac{\partial V}{\partial y} \quad E_z = -\frac{\partial V}{\partial z} \quad (\text{components of } \vec{E} \text{ in terms of } V)$$

$$\vec{E} = -\left( \hat{i} \frac{\partial V}{\partial x} + \hat{j} \frac{\partial V}{\partial y} + \hat{k} \frac{\partial V}{\partial z} \right) \quad (\vec{E} \text{ in terms of } V)$$

### Capacitance

$$C = \frac{Q}{V_{ab}} \quad (\text{definition of capacitance})$$

$$C = \frac{Q}{V_{ab}} = \epsilon_0 \frac{A}{d} \quad (\text{capacitance of a parallel-plate capacitor in vacuum})$$

$$\frac{1}{C_{eq}} = \frac{1}{C_1} + \frac{1}{C_2} + \frac{1}{C_3} + \dots \quad (\text{capacitors in series})$$

$$C_{eq} = C_1 + C_2 + C_3 + \dots \quad (\text{capacitors in parallel})$$

$$U = \frac{Q^2}{2C} = \frac{1}{2} CV^2 = \frac{1}{2} QV \quad (\text{potential energy stored in a capacitor})$$

$$u = \frac{1}{2} \epsilon_0 E^2 \quad (\text{electric energy density in a vacuum})$$

## Resistance, Current, EMF

$$I = \frac{dQ}{dt} = n|q|v_d A \quad (\text{general expression for current})$$

$$\vec{J} = nq\vec{v}_d \quad (\text{vector current density})$$

$$\rho = \frac{E}{J} \quad (\text{definition of resistivity})$$

$$\rho(T) = \rho_0[1 + \alpha(T - T_0)] \quad (\text{temperature dependence of resistivity})$$

$$R = \frac{\rho L}{A} \quad (\text{relationship between resistance and resistivity})$$

$$V = IR \quad (\text{relationship among voltage, current, and resistance})$$

$$V_{ab} = \mathcal{E} - Ir \quad (\text{terminal voltage, source with internal resistance})$$

$$P = V_{ab}I \quad (\text{rate at which energy is delivered to or extracted from a circuit})$$

$$P = V_{ab}I = I^2R = \frac{V_{ab}^2}{R} \quad (\text{power delivered to a resistor})$$

$$R_{eq} = R_1 + R_2 + R_3 + \dots \quad (\text{resistors in series})$$

$$\frac{1}{R_{eq}} = \frac{1}{R_1} + \frac{1}{R_2} + \frac{1}{R_3} + \dots \quad (\text{resistors in parallel})$$

$$\sum I = 0 \quad (\text{junction rule, valid at any junction})$$

$$\sum V = 0 \quad (\text{loop rule, valid for any closed loop})$$

## Area/Volume Formulae:

(1) Circle: Circum. =  $2\pi r$ ; Area =  $\pi r^2$

(2) Sphere: Area =  $4\pi r^2$ ; Volume =  $\frac{4}{3}\pi r^3$

(3) Cylinder: Area =  $2\pi rL$ ; Volume =  $\pi r^2L$

(4) Cone: Area =  $\pi r(r + \sqrt{h^2 + r^2})$  Volume =  $\pi r^2 \frac{h}{3}$

## Physical Constants:

(1) Electron charge mag:  $e = 1.602 \cdot 10^{-19} \text{C}$

(2) Electron mass:  $m_e = 9.11 \cdot 10^{-31} \text{kg}$

(3) Proton mass:  $m_p = 1.67 \cdot 10^{-27} \text{kg}$

(4) Coulomb constant:  $k \sim 9.0 \cdot 10^9 \text{N}^2\text{C}^2/\text{m}^2$

(5) Vacuum Permittivity:  $\epsilon_0 \sim 8.85 \cdot 10^{-12} \text{m}^2/\text{N}^2\text{C}^2$

## Answers (I think—I may have made a mistake!)

1. (a) b (b) c

2. (a) B (b) C

3. B

4. (a)  $-37.3 \text{nC/m}^2$  (b)  $3.00 \cdot 10^6 \text{ N/C}$

5.  $x = 1/2 \text{m}$ ;  $y = 1/2 \text{m}$

6. (a) inside conductor:  $E = 0$  (b)  $V_{ab} = 0 \text{V}$   
(c)  $353 \text{ V}$

7. (a)  $-x$  direction (b)  $3.34 \cdot 10^{-16} \text{ J}$

8. (a)  $4 \Omega$  (b)  $0.666 \text{A}$  (c)  $1.33 \text{W}$

9.  $6.00 \text{A}$

10.  $1.00 \text{ V}$

11. (a)  $0 \text{ A}$  (b)  $25 \text{V}$