

Name _____

Date _____

Section _____

MULTIPLE CHOICE. Choose the one alternative that best completes the statement or answers the question.

Find the distance $d(P_1, P_2)$ between the points P_1 and P_2 .

- 1) $P_1 = (7, 5); P_2 = (-7, -4)$ 1) _____
A) 5 B) $\sqrt{277}$ C) 126 D) $\sqrt{115}$

- 2) $P_1 = (-1, -2); P_2 = (6, -3)$ 2) _____
A) 48 B) $5\sqrt{2}$ C) 8 D) $48\sqrt{3}$

- 3) $P_1 = (1, 5); P_2 = (-11, 0)$ 3) _____
A) 169 B) 26 C) 14 D) 13

Solve the problem.

- 4) Find all values of k so that the given points are $\sqrt{29}$ units apart. 4) _____
 $(-5, 5), (k, 0)$
A) -3, -7 B) -7 C) 7 D) 3, 7

- 5) A motorcycle and a car leave an intersection at the same time. The motorcycle heads north at an average speed of 20 miles per hour, while the car heads east at an average speed of 48 miles per hour. Find an expression for their distance apart in miles at the end of t hours. 5) _____
A) $t\sqrt{68}$ miles B) $2t\sqrt{13}$ miles C) $52t$ miles D) $52\sqrt{t}$ miles

Find the midpoint of the line segment joining the points P_1 and P_2 .

6) $P_1 = (6, 3); P_2 = (8, 9)$

A) $(14, 12)$

B) $(-2, -6)$

C) $(7, 6)$

D) $(6, 7)$

6) _____

7) $P_1 = (-1, -7); P_2 = (3, -4)$

A) $(-2, -\frac{3}{2})$

B) $(-4, -3)$

C) $(1, -\frac{11}{2})$

D) $(2, -11)$

7) _____

8) $P_1 = (7, 1); P_2 = (-16, -16)$

A) $(-9, -15)$

B) $(\frac{23}{2}, \frac{17}{2})$

C) $(9, 15)$

D) $(-\frac{9}{2}, -\frac{15}{2})$

8) _____

Solve the problem.

9) If $(2, -1)$ is the endpoint of a line segment, and $(1, -6)$ is its midpoint, find the other endpoint.

A) $(0, -11)$

B) $(4, 9)$

C) $(-8, -3)$

D) $(0, 4)$

9) _____

Name the quadrant in which the point is located.

10) $(3, 15)$

A) I

B) II

C) III

D) IV

10) _____

SHORT ANSWER. Write the word or phrase that best completes each statement or answers the question.

Write the standard form of the equation of the circle.

11)

11)

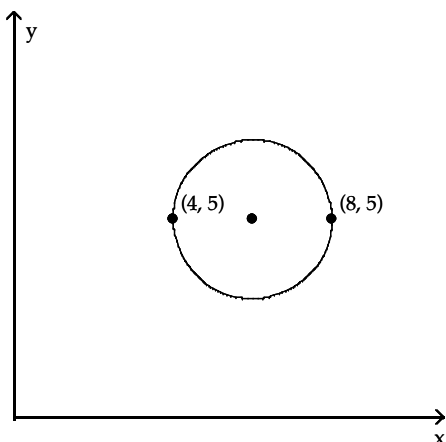

Graph the circle with radius r and center (h, k) .

12) $r = 5$; $(h, k) = (0, 2)$

12)

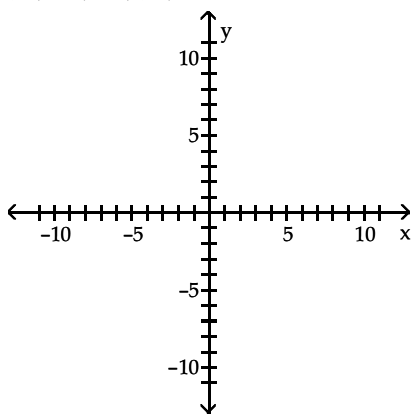

13) $r = 5$; $(h, k) = (2, 0)$

13)

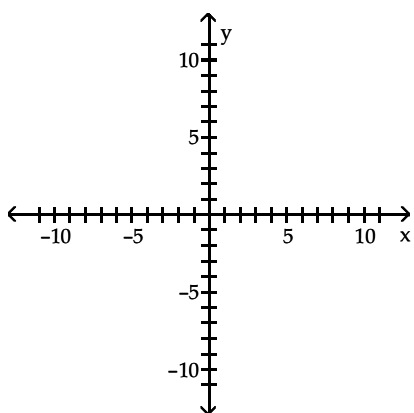

Find the center (h, k) and radius r of the circle. Graph the circle.

14) $x^2 + y^2 - 8x - 2y + 13 = 0$

14)

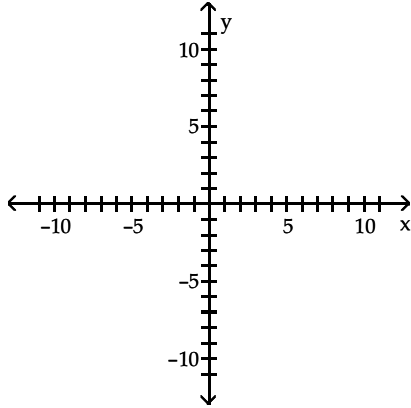

MULTIPLE CHOICE. Choose the one alternative that best completes the statement or answers the question.

Find the slope of the line through the points and interpret the slope.

15)

15)

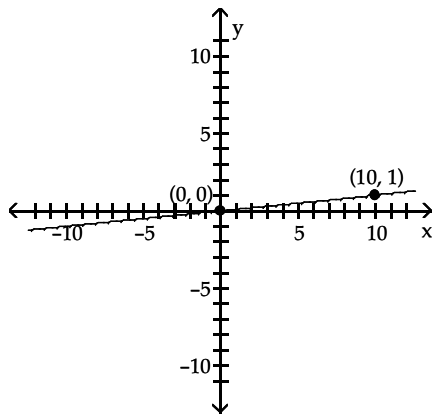

- A) -10 ; for every 1-unit increase in x , y will decrease by 10 units
- B) 10 ; for every 1-unit increase in x , y will increase by 10 units
- C) $\frac{1}{10}$; for every 10-unit increase in x , y will increase by 1 unit
- D) $-\frac{1}{10}$; for every 10-unit increase in x , y will decrease by 1 unit

SHORT ANSWER. Write the word or phrase that best completes each statement or answers the question.

Graph the line containing the point P and having slope m.

16) $P = (0, 5); m = \frac{2}{3}$

16)

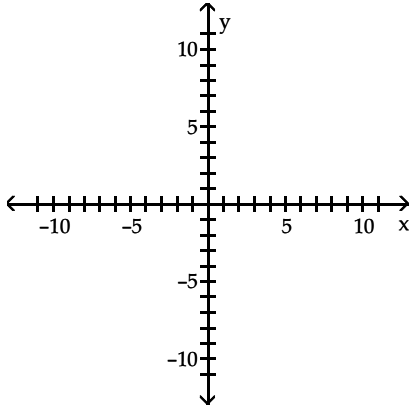

17) $P = (3, -3); m = 0$

17)

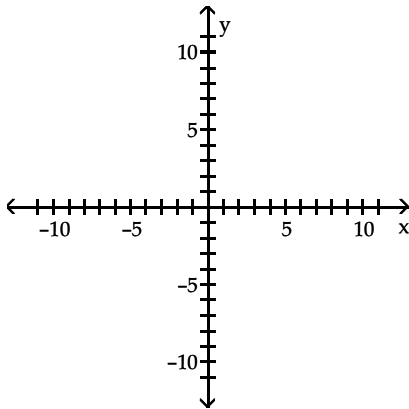

MULTIPLE CHOICE. Choose the one alternative that best completes the statement or answers the question.

Solve the problem.

18) Find the slope-intercept form of the equation of the line containing the points $(-3, -6)$ and $(1, -1)$.

18) _____

A) $y = -\frac{5}{4}x - \frac{9}{4}$

B) $y + 6 = \frac{5}{4}(x + 3)$

C) $y = \frac{5}{4}x - \frac{9}{4}$

D) $y = mx - \frac{9}{4}$

Find the slope-intercept form of the equation of the line with the given properties.

19) slope = 4; containing the point (-4, -10)

A) $y = 4x + 6$

B) $y = -4x + 6$

C) $y = -4x - 6$

D) $y = 4x - 6$

19) _____

Solve the problem.

20) The relationship between Celsius ($^{\circ}\text{C}$) and Fahrenheit ($^{\circ}\text{F}$) degrees of measuring temperature is linear. Find an equation relating $^{\circ}\text{C}$ and $^{\circ}\text{F}$ if 10°C corresponds to 50°F and 30°C corresponds to 86°F . Use the equation to find the Celsius measure of 29°F .

A) $C = \frac{9}{5}F - 80; -\frac{139}{5}^{\circ}\text{C}$

B) $C = \frac{5}{9}F - 10; \frac{55}{9}^{\circ}\text{C}$

C) $C = \frac{5}{9}F + \frac{160}{9}; \frac{305}{9}^{\circ}\text{C}$

D) $C = \frac{5}{9}F - \frac{160}{9}; -\frac{5}{3}^{\circ}\text{C}$

20) _____

Find an equation for the line with the given properties.

21) Perpendicular to the line $y = \frac{1}{4}x + 2$; containing the point (3, -2)

A) $y = -4x - 10$

B) $y = -\frac{1}{4}x - \frac{5}{2}$

C) $y = 4x - 10$

D) $y = -4x + 10$

21) _____

22) Perpendicular to the line $y = -7$; containing the point (4, 9)

A) $x = 9$

B) $y = 4$

C) $x = 4$

D) $y = 9$

22) _____

Write a general formula to describe the variation.

23) A varies directly with t^2 ; $A = 180$ when $t = 6$

A) $A = \frac{5}{t^2}$

B) $A = 30t^2$

C) $A = 5t^2$

D) $A = \frac{30}{t^2}$

23) _____

Solve the problem.

- 24) The wattage rating of an appliance, W , varies jointly as the square of the current, I , and the resistance, R . If the wattage is 12 watts when the current is 0.2 ampere and the resistance is 300 ohms, find the wattage when the current is 0.3 ampere and the resistance is 250 ohms. 24) _____
- A) 75 watts B) 22.5 watts C) 18,750 watts D) 150 watts

Write a general formula to describe the variation.

- 25) z varies jointly as the cube root of x and the cube of y ; $z = 2$ when $x = 125$ and $y = 2$. 25) _____
- A) $z = \frac{1}{20} \sqrt[3]{xy^3}$ B) $z = \frac{16 \sqrt[3]{x}}{5 y^3}$ C) $z = 20 \sqrt[3]{xy^3}$ D) $z = \frac{5 \sqrt[3]{x}}{16 y^3}$

Solve the problem.

- 26) The price per person of renting a bus varies inversely with the number of people renting the bus. It costs \$26 per person if 51 people rent the bus. How much will it cost per person if 96 people rent the bus? 26) _____
- A) \$13.81 B) \$48.94 C) \$16.90 D) \$188.31

Decide whether the pair of lines is parallel, perpendicular, or neither.

- 27) $3x - 8y = -1$ 27) _____
 $32x + 12y = -15$
- A) parallel B) perpendicular C) neither

Find an equation for the line with the given properties.

- 28) The solid line L contains the point (4, 3) and is perpendicular to the dotted line whose equation is $y = 2x$. Give the equation of line L in slope-intercept form. 28)

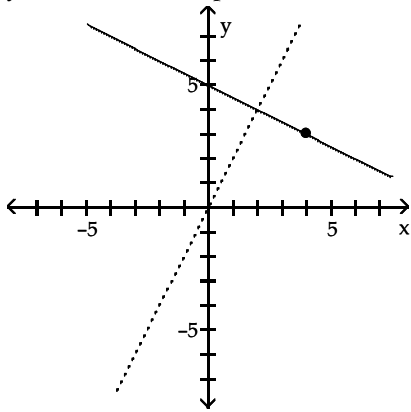

- A) $y = \frac{1}{2}x + 5$ B) $y - 3 = -\frac{1}{2}(x - 4)$ C) $y - 3 = 2(x - 4)$ D) $y = -\frac{1}{2}x + 5$

- 29) Parallel to the line $-5x - y = 6$; containing the point (0, 0) 29) _____
- A) $y = -\frac{1}{5}x$ B) $y = -5x$ C) $y = \frac{1}{5}x$ D) $y = \frac{1}{5}x + 6$

The equation of a line L is given. Find the slope of a line that is perpendicular to L.

- 30) $y = 5x$ 30) _____
- A) $\frac{1}{5}$ B) -5 C) 5 D) $-\frac{1}{5}$

Find an equation for the line with the given properties.

- 31) Parallel to the line $y = 5$; containing the point (8, 9) 31) _____
- A) $y = 8$ B) $y = 9$ C) $y = 5$ D) $y = -9$

Complete the statement.

- 32) Two nonvertical lines are perpendicular if and only if _____ . 32) _____
- A) the product of their slopes is -1
 - B) the product of their slopes is 1
 - C) their slopes are equal and they have the same y -intercepts
 - D) their slopes are equal and they have different y -intercepts

Find an equation for the line with the given properties.

- 33) The solid line L contains the point $(3, 4)$ and is parallel to the dotted line whose equation is $y = 2x$. 33) _____
Give the equation for the line L in slope-intercept form.

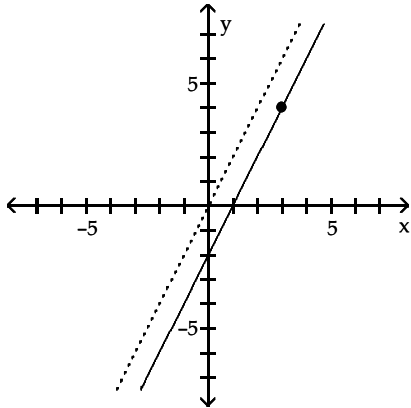

- A) $y = 2x + b$ B) $y - 4 = 2(x - 3)$ C) $y = 2x - 2$ D) $y = 2x + 1$

Complete the statement.

- 34) Two nonvertical lines are parallel if and only if _____ . 34) _____
- A) their slopes are equal and they have the same y -intercepts
 - B) the product of their slopes is -1
 - C) their slopes are equal and they have different y -intercepts
 - D) the product of their slopes is 1

SHORT ANSWER. Write the word or phrase that best completes each statement or answers the question.

Solve the problem.

- 35) Each month a gas station sells x gallons of gas at $\$1.92/\text{gallon}$. The cost to the owner of the gas station for each gallon of gas is $\$1.32$. The monthly fixed cost for running the gas station is $\$37,000$. Write an equation that relates the monthly profit, in dollars, to the number of gallons of gasoline sold. Then use the equation to find the monthly profit when 75,000 gallons of gas are sold in a month. 35) _____

MULTIPLE CHOICE. Choose the one alternative that best completes the statement or answers the question.

Find the general form of the equation for the line with the given properties.

36) Containing the points (5, 0) and (0, -4) 36) _____
A) $4x - 5y = 20$ B) $y = -\frac{4}{5}x + 5$ C) $4x + 5y = 20$ D) $y = -\frac{4}{5}x - 4$

37) Containing the points (-4, -9) and (0, 8) 37) _____
A) $-5x + 8y = -64$ B) $5x - 8y = -64$ C) $-17x - 4y = -32$ D) $17x - 4y = -32$

38) Containing the points (-7, 6) and (-4, 1) 38) _____
A) $5x - 3y = 17$ B) $13x + 5y = -57$ C) $-13x - 5y = -57$ D) $-5x - 3y = 17$

Find the slope and y-intercept of the line.

39) $9x - 10y = 90$ 39) _____
A) slope = $-\frac{9}{10}$; y-intercept = 9 B) slope = $\frac{9}{10}$; y-intercept = -9
C) slope = 9; y-intercept = 90 D) slope = $\frac{10}{9}$; y-intercept = 10

40) $x + y = 9$ 40) _____
A) slope = 0; y-intercept = 9 B) slope = -1; y-intercept = -9
C) slope = -1; y-intercept = 9 D) slope = 1; y-intercept = 9

Write the equation in slope-intercept form.

41) $5x - 6y = 2$

A) $x = \frac{6}{5}y + \frac{2}{5}$

B) $y = \frac{5}{6}x - \frac{1}{3}$

C) $-6y = -5x + 2$

D) $y = -5x + 8$

41) _____

Find the equation of the line in slope-intercept form.

42)

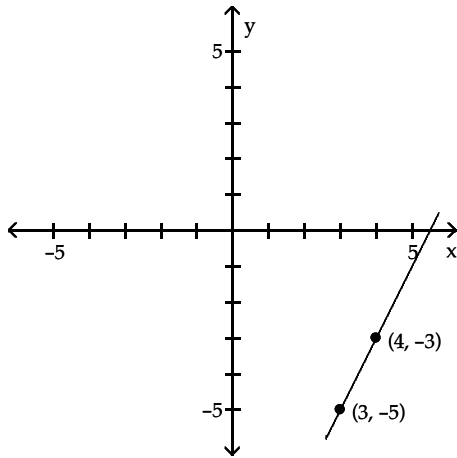

42)

A) $y = 2x + 13$

B) $y = 2x - 11$

C) $y = \frac{1}{2}x + \frac{8}{11}$

D) $y = 2x + 11$

Solve the problem.

43) Find an equation of the vertical line through the point (8.4, -5.5).

A) $x = -5.5$

B) $x = 2.9$

C) $x = 0$

D) $x = 8.4$

43) _____

44) Find an equation of the vertical line containing the point (7, 2).

A) $y = 7$

B) $x = 2$

C) $x = 7$

D) $y = 2$

44) _____

Find the slope of the line through the points and interpret the slope.

45) $(1, -3); (7, 8)$

45) _____

- A) $\frac{6}{11}$; for every 11-unit increase in x , y will increase by 6 units
B) $\frac{11}{6}$; for every 6-unit increase in x , y will increase by 11 units
C) $-\frac{11}{6}$; for every 6-unit increase in x , y will decrease by 11 units
D) $-\frac{6}{11}$; for every 11-unit increase in x , y will decrease by 6 units

Find the slope of the line containing the two points.

46) $(-7, -7); (-7, -6)$

46) _____

- A) 1 B) 0 C) -1 D) undefined

Find the center (h, k) and radius r of the circle with the given equation.

47) $x^2 + y^2 - 14x - 12y + 85 = 64$

47) _____

- A) $(h, k) = (6, 7); r = 8$ B) $(h, k) = (-7, -6); r = 64$
C) $(h, k) = (-6, -7); r = 64$ D) $(h, k) = (7, 6); r = 8$

48) $x^2 + y^2 + 8x + 12y = -3$

48) _____

- A) $(h, k) = (6, 4); r = 49$ B) $(h, k) = (-6, -4); r = 7$
C) $(h, k) = (4, 6); r = 49$ D) $(h, k) = (-4, -6); r = 7$

Write the standard form of the equation of the circle with radius r and center (h, k) .

49) $r = 11; (h, k) = (0, -10)$

49) _____

- A) $(x + 10)^2 + y^2 = 121$ B) $x^2 + (y - 10)^2 = 11$
C) $x^2 + (y + 10)^2 = 121$ D) $(x - 10)^2 + y^2 = 121$

50) $r = 7$; $(h, k) = (-1, -4)$

A) $(x + 1)^2 + (y + 4)^2 = 49$

C) $(x + 1)^2 + (y + 4)^2 = 7$

B) $(x - 1)^2 + (y - 4)^2 = 7$

D) $(x - 1)^2 + (y - 4)^2 = 49$

50) _____

Find the center (h, k) and radius r of the circle with the given equation.

51) $(x - 7)^2 + (y + 9)^2 = 100$

A) $(h, k) = (-9, 7)$; $r = 10$

C) $(h, k) = (7, -9)$; $r = 100$

B) $(h, k) = (7, -9)$; $r = 10$

D) $(h, k) = (-9, 7)$; $r = 100$

51) _____

Answer Key

Testname: PRACTICE SINGLE SPACED

- 1) B
- 2) B
- 3) D
- 4) A
- 5) C
- 6) C
- 7) C
- 8) D
- 9) A
- 10) A
- 11) $(x - 6)^2 + (y - 5)^2 = 4$
- 12)

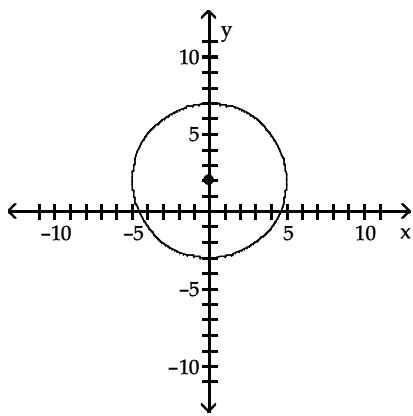

13)

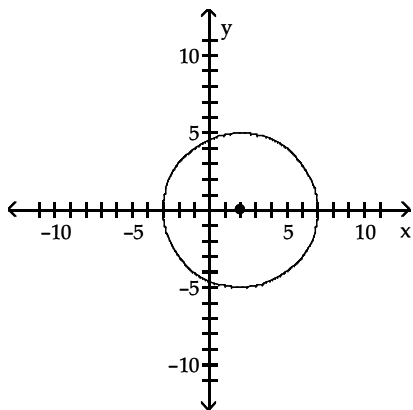

14) $(h, k) = (4, 1); r = 2$

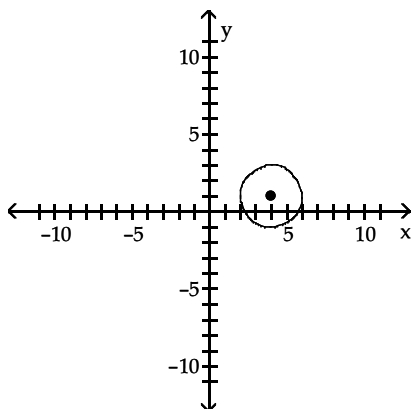

Answer Key

Testname: PRACTICE SINGLE SPACED

15) C

16)

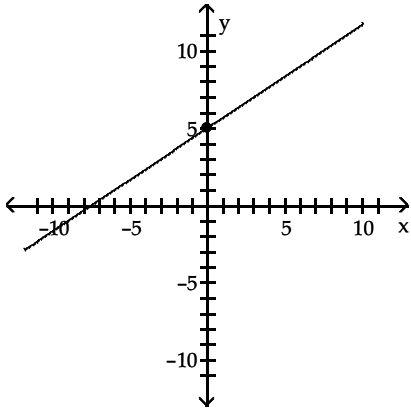

17)

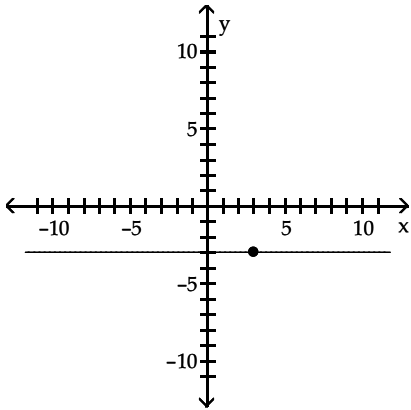

18) C

19) A

20) D

21) D

22) C

23) C

24) B

25) A

26) A

27) B

28) D

29) B

30) D

31) B

32) A

33) C

34) C

35) $P = 0.60x - 37,000$; \$8000

36) A

37) D

38) D

39) B

40) C

Answer Key

Testname: PRACTICE SINGLE SPACED

- 41) B
- 42) B
- 43) D
- 44) C
- 45) B
- 46) D
- 47) D
- 48) D
- 49) C
- 50) A
- 51) B